

MAGNETIC SEPARATOR

THE CLEVER SAFETY SOLUTION

10.000 G



The JACOB magnetic separator extracts ferrous contaminants quickly and easily from free-flowing bulk materials and exhaust air with low conveying pressure. It can be applied in any industry where ferrous metal needs to be separated from the product flow. One such application is when downstream machinery needs to be protected, for example in plant engineering or in the plastics industry. Another application is the safe production of food products such as flour or sugar.

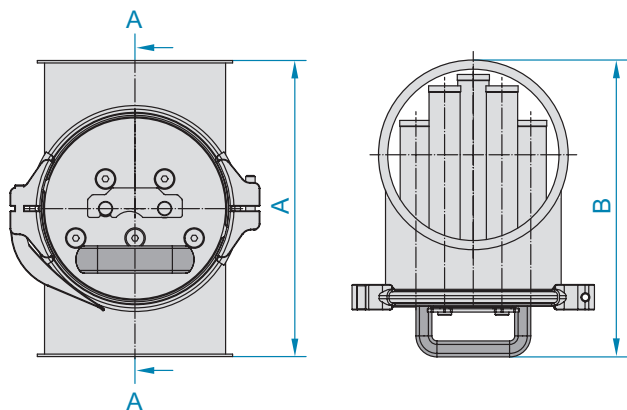

CLEVER DESIGN

- **Strong magnets** – up to nine neodymium tubes separate even the smallest ferrous particles from bulk and exhaust air.
Max. magnetic induction (G) – on the surface of tube (+/-10 %): 10.000 Gaus.
- **Compact and robust** – consisting of multiple magnetic tubes that are protected by a stainless-steel cover, a T-piece and a pull-ring connection with a detectable design seal.
- **Easy to clean** – pull the separator from the pipework system, remove the magnets from the cover, and all ferrous pieces and particles will simply fall off the cover surface.
- **Increased food safety** – combine the magnetic separator with sealings from the JACOB DETECTABLE DESIGN line.

DN	Item Number	Thickness and Material of T-piece	Price EUR	Weight kg	Number of tubes	Dimensions in mm			
						A	B	Ø d	Min. distance between magnetic tubes
100	1110324003	1,5 mm, V2A	1766,00	4,5	3	200	205	100	17
150	1115324005	1,5 mm, V2A	2902,00	8,5	5	250	260	150	22
200	1120324007	1,5 mm, V2A	4196,00	14,0	7	300	310	200	22
250	1125324009	1,5 mm, V2A	5714,00	20,0	9	350	360	250	22
300	1130324009	1,5 mm, V2A	6707,00	26,5	9	400	410	300	22

Other diameters are possible on request
Stainless steel V2A = AISI 304/304L

FR. JACOB SÖHNE GMBH & CO. KG

Sales International
T +49 571 9558-201
sales@jacob-rohre.de
www.jacob-group.com

Version 1, stand 09/2022

